

Scrutinise your machine.

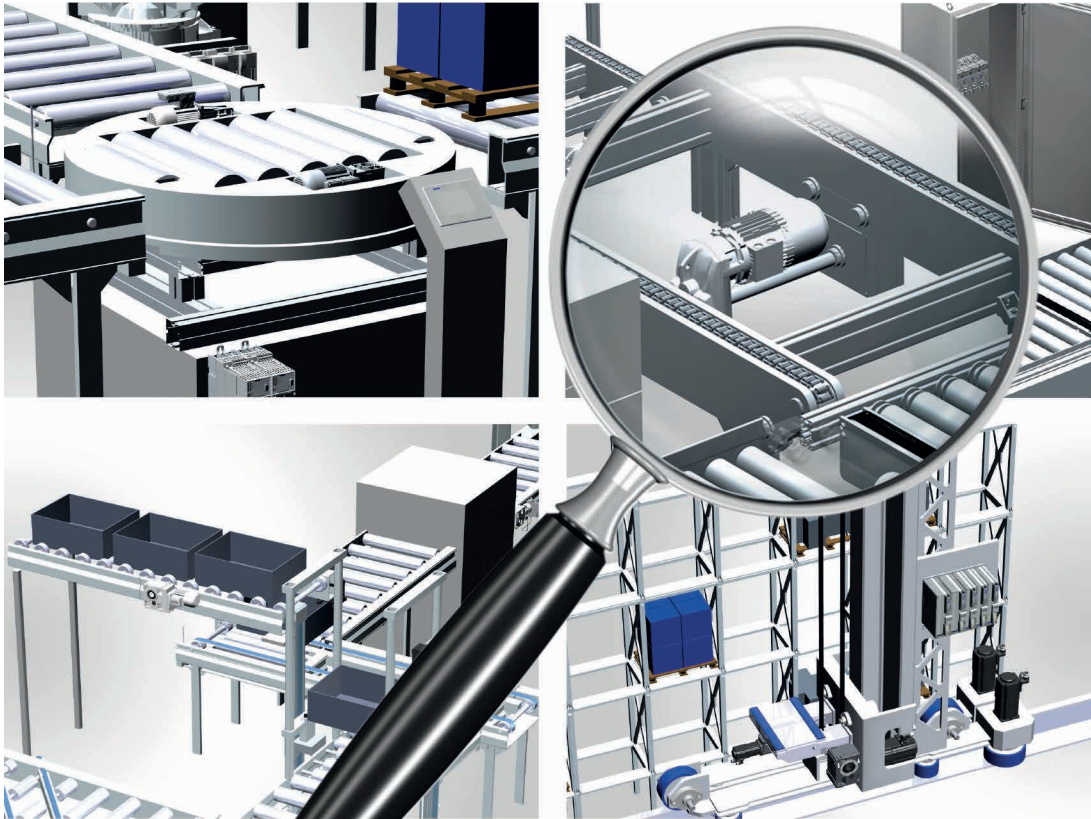

You know your machine extremely well. Together, we can get to know it even better and pave the way for optimisation; for example, we can unlock performance potential and detect the possible weak points or risks.

A system analysis carried out by our experts at Lenze offers you a profound insight into the current status of your system and a medium-term outlook for its future. This provides an excellent starting point for taking preventative action to prevent standstills and can significantly improve the level of responsiveness in the event of an emergency.

Highlights

- Clear information throughout about the current status of the drive technology installed
- Analysis of the risks and weak points relating to:
 - the availability of the system
 - the factors influencing costs in the system
- Recommendations for optional measures to:
 - reduce downtime
 - optimise or extend the life cycle of the machine
- Performance reserves highlighted
- Reduced variants in the product range lead to improved responsiveness in the event of a standstill

Machine analysis

Service module inspection

We offer you:

- A professional inventory of the drive components and an availability check if an inventory is yet to be carried out
- Status monitoring of the drive and automation components installed
- Data backup for all the Lenze drive systems installed, to make sure they are up and running again as quickly as possible after downtime
- Identification and analysis of errors; recommendations for remedial measures to be taken
- Detailed system report including analysis results:
 - interpretation of results
 - preventative measures
 - recommended actions
- Checking and updating of the existing stocks
- Free disposal of redundant drives

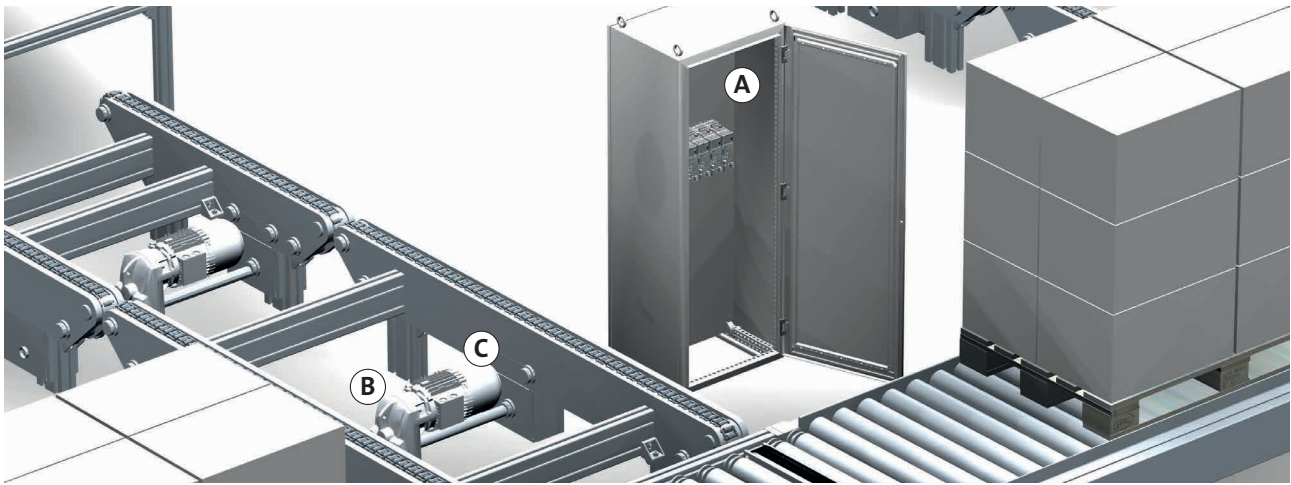

A Control cabinet

- Program and data backup
- Read-out of operating hours and log of mains connection times
- Read-out and analysis of the fault memory
- Thermal imaging of the control cabinet

B Gearbox

- Analysis of the state of wear, including:
 - visual inspection of the electromechanics
 - vibration monitoring
 - thermal imaging of the gearbox
 - brake diagnosis (state of wear)
 - oil analysis to assess the progression of the wear

C Motors

- Critical drive components identified; stocks and availability checked
- State of wear assessed by means of visual inspections and measurements
- Electrical engineering and electromechanics analysed

Complete overview

- Database provided and comprehensive report prepared along with recommendations for action to be taken
- Axis documentation inspected; operating instructions supplemented or updated where necessary
- Installation conditions documented with photographic material
- Thermal imaging used to analyse weak points or overloading:
 - thermal imaging report from the control cabinet to the gearbox
- Service concept derived for the system operator