

**Optimizing
automation
for winding
applications**

WINDING

**Technology
and experience
you can rely on**

**A partnership
you can trust**



Customer-centric approach

Our top priority is collaborating closely with you as a partner, not just a product manufacturer. Automation can be complex; therefore, we aim to turn your challenges into scalable solutions that stand the test of time. Whether enhancing existing equipment or designing new machinery, we're committed to setting your ideas in motion.

With over 75 years of experience optimizing automation, Lenze's mission is to deliver engineering resources and innovative products at every stage of your automation and winding challenges, ensuring your success is our success. From initial planning to final equipment commissioning, your success is not just a goal but the very measure of our partnership in progress.



Open system architecture

How can you plan your automation environment for the next decade and beyond? The answer lies in scalability and flexibility, the building blocks for a rapidly changing environment. With a legacy focused on customer success, we are committed to open-system architecture, a foundation for solving your most vexing challenges.

CODESYS at the core — We are committed to delivering the best value proposition for your automation challenges while allowing maximum scalability and efficient integration of the best products available for your business.

A prime example of this commitment includes our innovative solutions like **EASY Starter** and **FAST** pre-coded function blocks, accessed through our **PLC Designer**. These modules vastly simplify commissioning and motion control functions, minimizing the need for coding while freeing up engineering design resources for critical business needs.

Hardware and software working in tandem for winding applications

Drives

- **i950 cabinet**
Servo drive
- **i750 cabinet**
Multi-axis servo drive
- **i550 cabinet**
Variable frequency drive
- **i550 motec**
Decentralized variable frequency drive

Motors

- **MQA**
Asynchronous servo motor
- **MCA**
Asynchronous servo motor
- **MCS**
Synchronous servo motor
- **MF**
VFD optimized three-phase motor

Software

- **EASY Engineering Tools**
- EASY Starter
- EASY System Designer
- **Lenze FAST**
Application software toolbox

Common winding application areas

- Traversing
- Precision tension
- Robust materials
- High variance
- Web tension
- Constant speed



The Lenze automation platform — optimized for compatibility

The Lenze automation ecosystem delivers high-quality, reliable products from the drive shaft to the cloud. Moreover, our commitment to sustainable manufacturing processes and energy efficiency is reflected in our vision to lead the industry toward a better future-built automation environment.

Additionally, we are committed to an open development platform allowing customers to choose the best products for their automation challenges, which is reflected in our partners' easy integration of Lenze components.

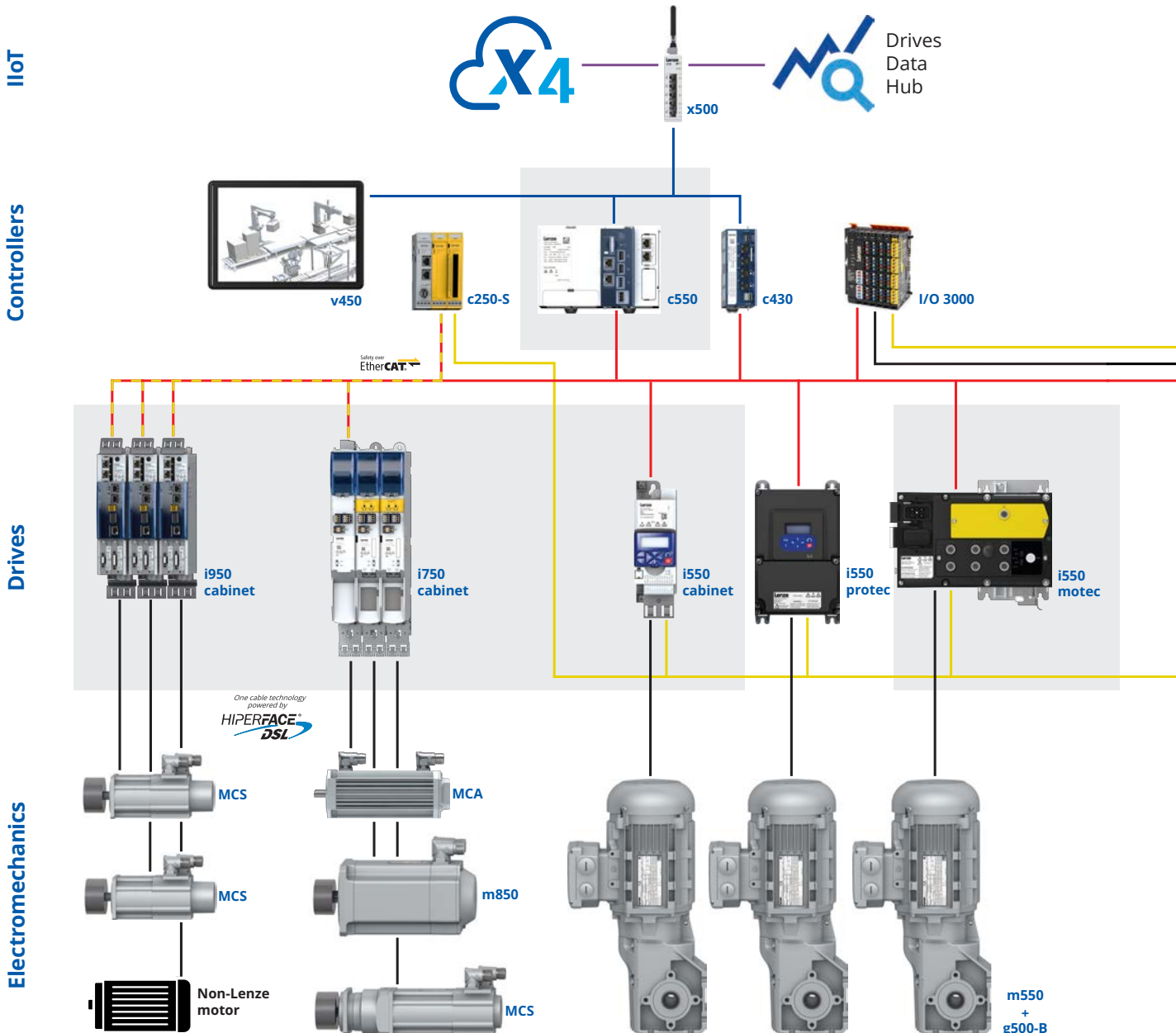

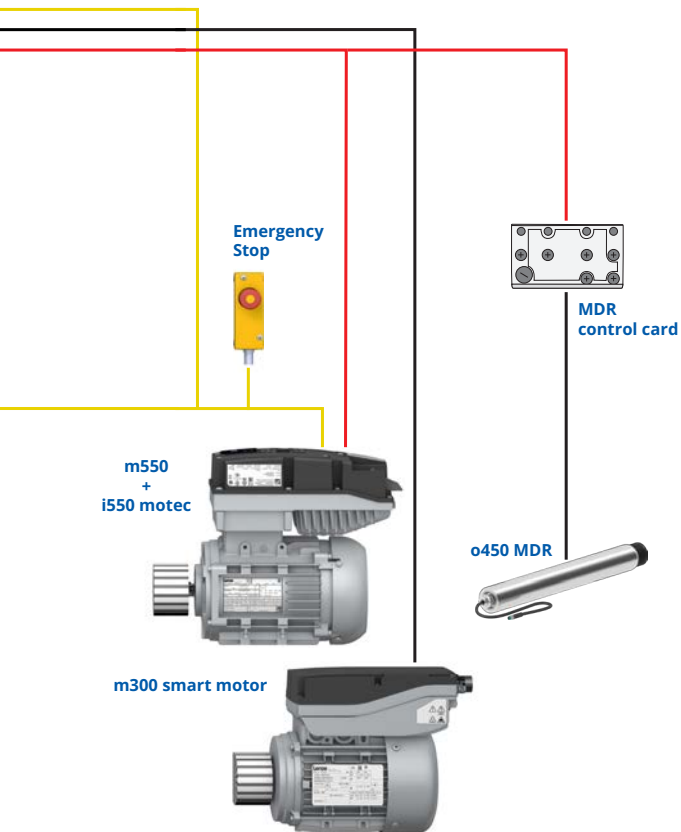
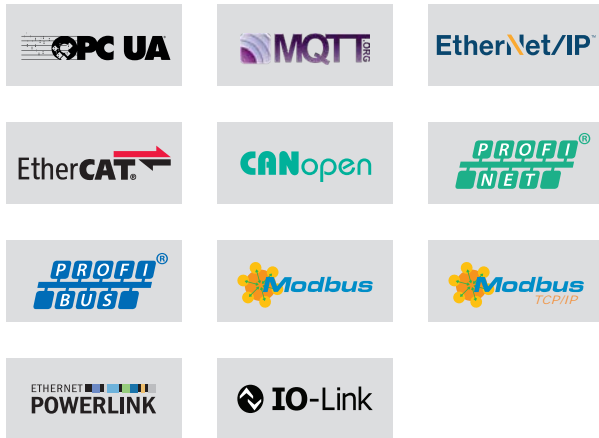

Drives — benefits, technology and systems



i950 cabinet
Servo drive

- Reliable, integrated, and open — Onboard I/O, CODESYS PLC, modular communication, modular feedback, CODESYS WebVisu option available
- Project savings — Reduce engineering effort and cost with integrated PLC on board and less hardware components
- Narrow profile — Allows for smaller control cabinets
- Auto-tuning — For quick controller adjustments
- Less cabling — One Cable Technology (OCT)
- Simplified integration — Programming is easy with Lenze FAST pre-coded function blocks
- Safety on board — Integrated safety protocols

The intelligent i950 cabinet servo drive offers advantages where high accuracy is needed.

Experience seamless integration within modular systems. Designed with ready-to-use technology applications for simplifying parameterization eliminating the need for complex programming.



i750 cabinet
Multi-axis servo drive

- Regen management — Common DC bus
- Multi-axis — Single or double-axes capable
- Shorter installation time — Single point of fusing
- Narrow profile — (50mm), ideal for double-axes
- Auto-tuning — For quick controller adjustments
- Less cabling — One Cable Technology (OCT)
- Simplified integration — Programming is easy with Lenze FAST pre-coded function blocks

The i750 cabinet multi-axis servo drive provides everything for precise and dynamic motion control in complex multi-axis applications.

Advanced safety functions and One Cable Technology reduce wiring and control complexity, while data-based functions and IIoT enable innovative motion control concepts.

Motors

MQA
Asynchronous
servo motor



Available in various RPM ranges, the MQA uses its rotary fan cooling to optimally run large printing and converting applications.

MCA
Asynchronous
servo motor



The MCA features smooth operation with a low degree of torque ripple. It is designed for printing and converting applications, and it is ideal for achieving high accuracy at low speeds.



i550 cabinet
Variable frequency drive (VFD)

- Cost efficient — Low installation cost and improved ROI
- Compact size — Reduced footprint for cabinet installation
- Flexible communications — Modular fieldbuses

The i550 cabinet variable frequency drive is a compact control cabinet device with scalable functionality. It is versatile, reliable, and easy to use.

Maximum flexibility as a complete device or as individual parts (Power Unit, Control Unit and Safety Unit).



i550 motec
Decentralized variable frequency drive

- Mounting flexibility — Wall or motor mounting provides maximum installation options
- Energy savings — Full Line regen capability eliminates brake resistors while feeding power back to the mains
- Adverse climates — Designed to perform under demanding conditions, offering additional installation options
- Easy installation — Connectorized unit with plug-in cabling saves time and avoids wiring issues
- Minimized variances — Open and closed loop motor control for varying control, precision, and torque

The i550 motec provides class-leading flexibility, efficiency, and convenience in a rugged, decentralized VFD.

Designed for easy integration and energy savings, the i550 motec is more efficient, less complex, and provides a safer alternative for decentralized challenges

MCS
Synchronous
servo motor



The MCS features a compact form factor and a neodymium magnetic rotor to achieve quick start/stop in highly dynamic applications.

MF
VFD optimized
three-phase motor



Functionally equivalent to a servo motor, the MF boasts 4 pole/120Hz operation and full torque at 3,600 RPM. It pairs well with gearing or belting applications and is two sizes smaller than typical IE3 motors.

Application product guide

Winding System

Machine Requirements

Synchronous/Asynchronous servo control

Precise tension with high demand on position accuracy

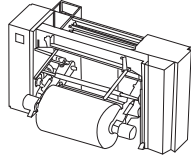

- Two-axis traversing system
- Positioning control
- Smooth traversing
- Tension control

- Adjustable layer pattern
- Adaptable coil geometry with radius correction
- Resonance-free motion

Robust materials with buffer (loop, dancer)

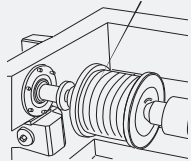

- Two-axis traversing system
- Speed-based closed loop
- Continuous winding/unwinding in processes with varying speed
- Cost-effective traversing of robust material

- Easy integration into existing lines
- Easily adjusts through various product patterns
- Guaranteed level lay all materials

Precise with high variance (without traversing)

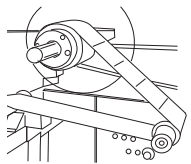

- One-axis winding system
- Speed control
- Large tension setting range due to the different materials
- Tension sensor on the material

- Easy integration into existing lines
- Minimize web breaks with more precise speed regulation
- Regen management

Induction motor control

Precise web tension

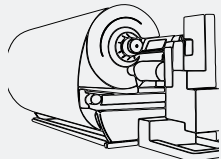

- One-axis winding system
- Torque control
- Tension setting range varies with the different materials.
- Tension sensor on the material is optional.

- Easy integration into existing lines
- Internal diameter calculation
- Automatic web break detection
- High acceleration/deceleration capabilities with full line regen

Precise tension with high demand on speed constancy

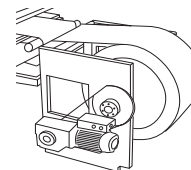

- One-axis winding system
- High-precision speed control
- High-line speed control
- Wide range of speed/diameter variation
- High-control response to process disturbance

- Easy integration into existing lines
- Transducer/dancer feedback
- Minimize web breaks with more precise speed regulation
- Minimize velocity ripple

Pick up web or round materials

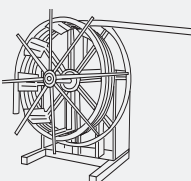

- One-axis winding system
- Tension control open loop, torque-based
- Simple winding of web or round materials
- Beneficial cost/performance ratio for rigid self-sustaining materials

- Easy integration into existing lines
- Dancer or tension-controlled regulated winding or unwinding without sensor
- Regen management

Lenze

Drive solution	Drives	Motor flexibility*	Software
<ul style="list-style-type: none"> - Easy integration into existing lines - Guaranteed level lay all materials 	i950 cabinet i750 cabinet	<ul style="list-style-type: none"> - Synchronous and asynchronous - Wide range of dynamic performance allows for a huge moment of inertia - Typical motor power 0.1kW ... 18kW (1/8HP ... 25HP) 	<ul style="list-style-type: none"> - Drive-based camming - Winder libraries in Lenze FAST pre-coded function blocks - Parameterize with FAST or program in PLC Designer (CODESYS)
<ul style="list-style-type: none"> - Low dynamic, semi stationary, no response to load mismatch - Simple PID-Controller (loop or dancer control) - High load mismatch ratios - Speed forward signal via HTL or fieldbus 	i950 cabinet i750 cabinet i550 cabinet	<ul style="list-style-type: none"> - Synchronous and asynchronous - Typical motor power 0.1kW ... 110kW (1/8HP ... 150HP) 	<ul style="list-style-type: none"> - Drive-based camming - Winder libraries in Lenze FAST pre-coded function blocks - Parameterize with FAST or program in PLC Designer (CODESYS)
<ul style="list-style-type: none"> - Integration with non-Lenze controller using system bus between drives - Handling of high-load mismatch ratios 	i950 cabinet i750 cabinet i550 motec	<ul style="list-style-type: none"> - Synchronous and asynchronous closed-loop control - Typical motor power 0.1kW ... 110kW (1/8HP ... 150HP) 	<ul style="list-style-type: none"> - Winder libraries in Lenze FAST pre-coded function blocks - Parameterize with FAST or program in PLC Designer (CODESYS)
<ul style="list-style-type: none"> - Low dynamic, semi-stationary, no response to load mismatch - Simple PID-Controller (loop or dancer control) - Secondary load-side encoder port - High-load mismatch ratios - Speed forward signal source HTL or fieldbus 	i950 cabinet i750 cabinet i550 cabinet	<ul style="list-style-type: none"> - Synchronous and asynchronous - Typical motor power 0.1kW ... 110kW (1/8HP ... 150HP) 	<ul style="list-style-type: none"> - Winder libraries in Lenze FAST pre-coded function blocks - Parameterize with FAST or program in PLC Designer (CODESYS)
<ul style="list-style-type: none"> - Custom control algorithms - Maintain accurate synchronization during acceleration - Integration with non-Lenze controller using system bus between drives 	i950 cabinet i750 cabinet i550 cabinet	<ul style="list-style-type: none"> - Synchronous and asynchronous closed-loop control - Typical motor power 0.1kW ... 110kW (1/8HP ... 150HP) 	<ul style="list-style-type: none"> - Winder libraries in Lenze FAST pre-coded function blocks - Parameterize with FAST or program in PLC Designer (CODESYS)
<ul style="list-style-type: none"> - No diameter calculation - No friction or acceleration compensation 	i950 cabinet i750 cabinet i550 motec	<ul style="list-style-type: none"> - Synchronous and asynchronous closed or open loop control - Typical Motor Power 0.1kW ... 110kW (1/8HP ... 150HP) 	<ul style="list-style-type: none"> - Winder libraries in Lenze FAST pre-coded function blocks - Parameterize with FAST or program in PLC Designer (CODESYS)

* Other combinations with induction and servo motors are available.

Drive systems — Traversing

Typical challenges











- Engineering resources spent on programming and code writing
- Need for individual drives to serve each winding spool
- Edge build-up requires ad-hoc solutions that may be difficult to replicate

Lenze solution

- Individual drive-based camming
- Seamless Integration with other brands
- Reduced engineering time, with FAST software modules for minimal coding
- Solves edge build-up

Take advantage of **plug-and-play modularity** with a full end-to-end drive system available in three configurations.

Each present minimal code writing of drive-based automation suitable for any operation.

	Modular			Controller based
System	Synchronous decentralized	Asynchronous decentralized	Asynchronous with regen	Synchronous centralized
Application	For use in high precision critical layering applications	For use in high HP range applications	For use in dynamic applications with power regeneration	For use in high axis count, DC bus bar solutions
Motors	<ul style="list-style-type: none"> - Servo - Induction - PMAC 	<ul style="list-style-type: none"> - Induction - PMAC 	<ul style="list-style-type: none"> - Induction - PMAC 	<ul style="list-style-type: none"> - Servo - Induction - PMAC
Motion	 i950 cabinet	 i950 cabinet	 i950 cabinet	 c550 controller
Tension	 i950 cabinet	 i550 cabinet	 i550 motec	 i750 cabinet
Software				

EASY Engineering tools

Planning



EASY System Designer

Drive sizing for your machine

The Lenze EASY System Designer supports machine planners with drive selection, taking into consideration functionality, performance, and energy consumption.



Implementation



PLC Designer

Easily implement PLC projects for motion control

This tool allows program creation and product commissioning based on CODESYS. PLCOpen certified components make it easy to implement even extensive PLC projects. IEC 61131-3 standard.



Lenze FAST

Ready-to-use pre-coded function blocks for the i950 and i750

Our FAST pre-coded function blocks, allow you to implement many complex motion tasks utilizing pre-made functionality in your machine.



[Overview video](#)

Modular architecture

With the Lenze FAST pre-coded function blocks, you achieve modularization of machine functions and standardization of interfaces, ultimately reducing engineering time, cost, and complexity.

Costs and complexity under control

Pre-tested, documented, and reusable pre-coded function blocks lead to improved quality and optimized resource management. This means you can easily reuse, expand, and maintain control — efficiently, reliably, and safely.

Pre-coded function blocks

Winder



Traversing



Flex Cam



Speed ctrl.



Cross Cut



Register



Tension



Flying saw



Temperature



Virtual master



Table position



Electrical shaft



Operation



EASY Starter

Quickly parameterize, commission, and diagnose

Supports service technicians with the commissioning and maintenance of your machines thanks to easy-to-use diagnostic and parameterization dialogs.



One license has you covered

Learn more about licensing the full suite of EASY Engineering tools



Technical data



Drives



Servo motor



MF motor

Lenze
engineered to win

800-217-9100
info.us@lenze.com

Lenze Americas
630 Douglas St,
Uxbridge, MA
01569

lenze.com